

**Wudtone CP Holy Grail, CP Vintage 50s  
upgrade fitting instructions:**

**Wudtone**  
*Guitar Innovation*

Thank you for choosing a Wudtone tremolo

1 Remove the existing trem.

Remove the plate which covers the trem cavity on the back of the guitar and then take off the strings.

Then remove each spring by first un-hooking off the trem claw and then pulling out of the block. This may need a pair of pliers to hold the spring, twist from side to side and pull up to help release the spring from the block as they are sometimes quite a tight fit.

Once the strings and springs are removed, remove each of the six mounting screws, so the trem unit can be lifted off.

2 With the old trem unit removed take the .5mm shim supplied with the Wudtone trem and place it over the six holes.



Then place the Wudtone Tremolo unit in position on top of the shim. With or without saddles fitted it doesn't matter.

### 3 Setting the Wudtone bearing screw height correctly

The Wudtone trem is designed to operate with a constant pivot point ( point A on the diagram below) and give you as guitarist some 20 degrees of tilt. This is plenty of tilt for quite extreme dive bomb trem action as well as up pitch and down pitch whilst delivering total tuning stability. Whilst the plate is tilting it is maintaining contact with the body through the shim via arc B and this will de-compress and transform the dynamics of your guitar.

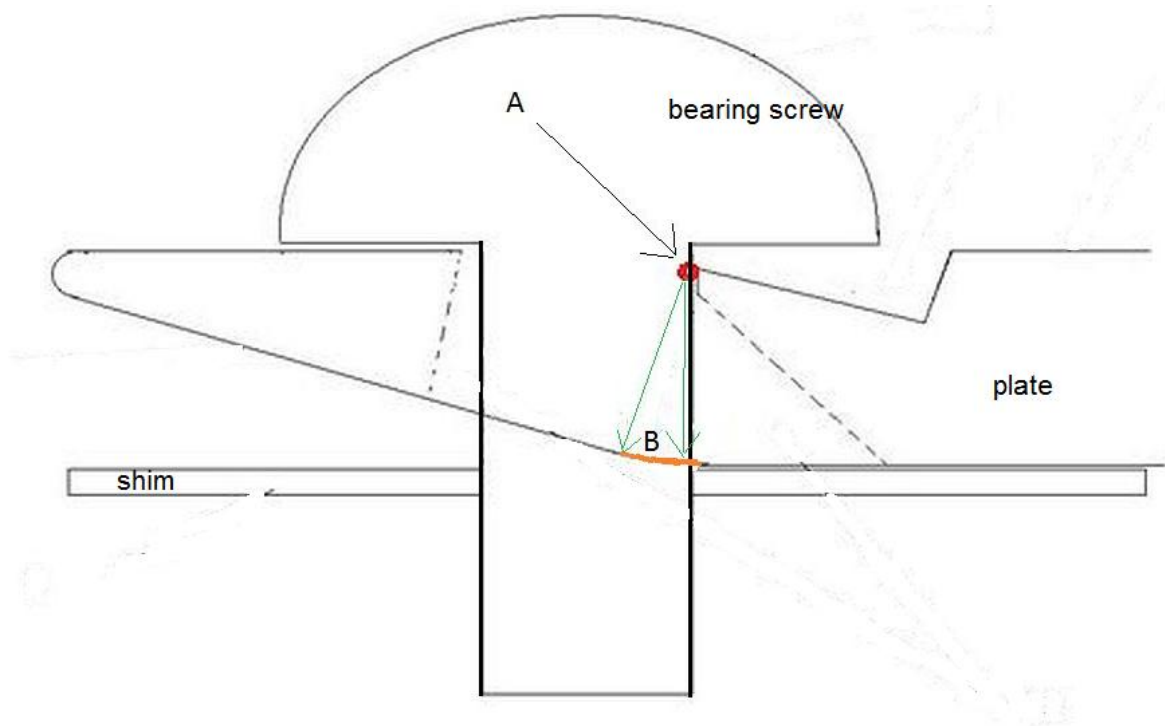

Before any springs or strings are fitted , it is important to set correctly the height of each bearing screw.

Insert the two outer screws which will be under the 1st string and the sixth string. Be sure to use the supplied Wudtone bearing screws.

Before the bearing screws are screwed down you will notice that the plate surface maybe slightly lower at the back edge and so the angle between the bearing screws and the top of the plate is more than 90 degrees.



Screw the bearing screw (which will be under the sixth string) down until the screw head touches the plate and then as you screw down a little more you will see the back edge of the plate lift. Bring the screw down until the plate is just sat nicely flat on the shim. In this position the angle between the vertical of the bearing screws and the top of the plate should be at 90 degrees as per the pic below and this is the correct height setting.



Experiment , slightly over tightening each screw and then backing off. Too tight and the plate will be lifted too much at the back edge. Too slack and the plate will be lower at the back edge and so at more than 90 degrees to the bearing screws.

Bring down the other outer and the four inner bearing screws to just touch the surface of the plate and ensure all the screws are set at the same exact height and with the plate sat flat on the shim as below.

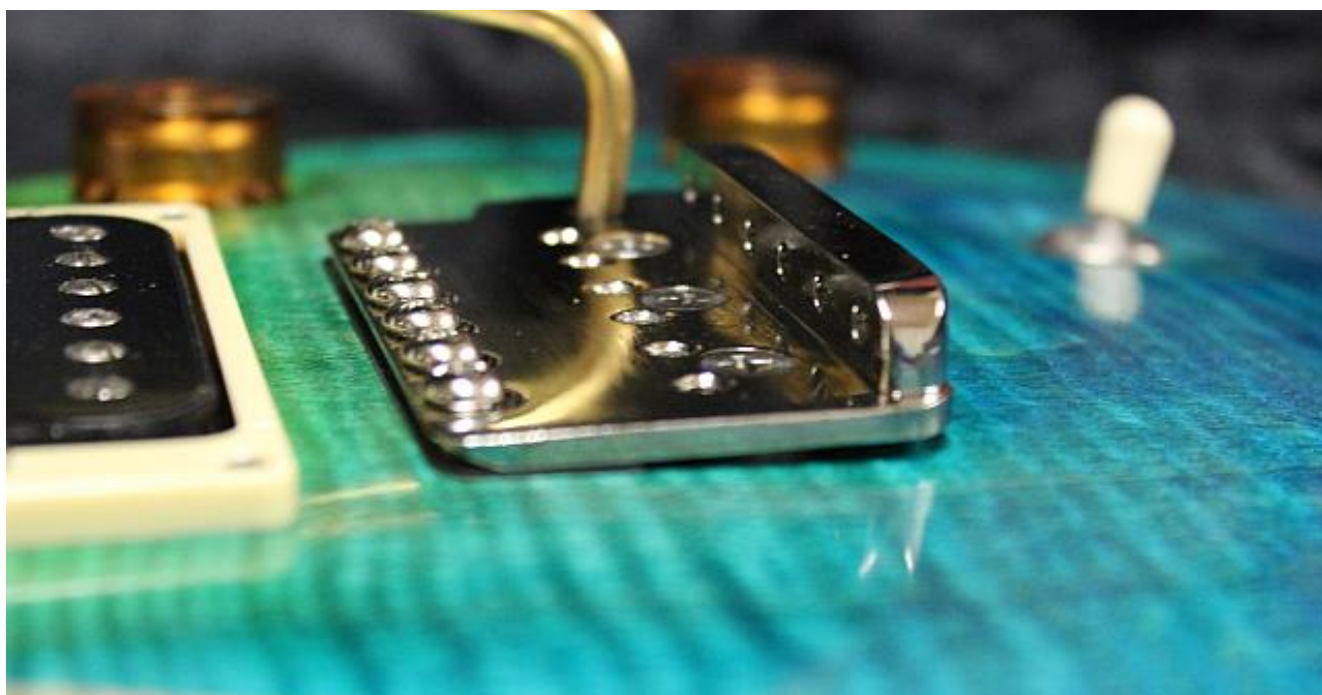

Once you have set the height of each bearing screw correctly. Test the free tilt of the trem unit.



It should tilt up and down freely and with little effort but it will not be able to move up and down ( in a vertical plane ) at the front. If it can move up and down at the front the bearing screws may be too slack . If there is any resistance to a free tilt, check in the trem cavity in case anything restricting the free movement of the block underneath.

#### 4 Fitting springs and strings

First slacken the claw a little ( just 2/3 turns anti clockwise with each of the two claw screws) and fit the same number of springs in the same positions as before and string up. If you are fitting different gauge strings the number of springs and /or the claw position may need further adjustment and so it helps to use the same gauge to start with.

#### 5 Setting the claw for required up pitch

First fit the trem arm by inserting the arm down through the nylon bush in the block and turning clockwise ( whilst pushing down gently) to engage in the threads below. You can vary the stiffness of the arm swing with more or less turns into the threads.

#### UP pitch setting

As a starting point aim for one full tone of up pitch . Tune up the guitar.

Now adjust the claw screws ( you will most likely need to screw them back in a little if you have used the same gauge strings) until :

the stable position has the rear edge of the trem unit, lifted up from the 90 degree position, just enough, to give you a full tone of up pitch, when you pull up on the trem arm, to move the plate back into the 90 degree position.

You will probably have to keep re tuning and then making finer and finer adjustments to the claw screws until you have it where you want it. Basically enough up pitch , but not too much. In the stable

position , there is usually some 5-6mm gap between the rear edge of the bridge plate and the body. This is usually enough movement to give a full tone of up pitch as well as plenty of down pitch trem

Now you are ready to enjoy a new enhanced guitar experience.

The first thing you will notice is how much more vibration there is against your body and in your neck hand. Essentially the bridge is more dynamically efficient at getting the energies you put into the strings into the body which then loop back into the strings and your output / tone. Think of the guitar as a battery for energies you are putting into it, the Wudtone trem a more efficient way to get more energy into that battery.

The guitar will feel more responsive and you won't have to play it as hard to get more out.

Chords will sustain longer , individual notes will last longer and you will find a de-compressed level of light and shade at your fingertips. Indeed you are likely to find that the dynamic efficiencies and changes will inspire and bring out more of the dynamic in you, as the guitar player.

You should hear more detail, more clarity with any frequency.

The trem action should be smooth and very sensitive ( great for shimmering chords ). More aggressive use of the trem should not incur any tuning issues whatsoever.

Remember you may need to check and set intonation in the usual way with the intonation screws. Set action preference using the saddle height screws.

The Wudtone trem comes as standard with 8mm and 10mm saddle height screws fitted to the saddles.

Also included are 6mm and additional 8mm screws

Once you have settled down with the set up, preferred action, make sure there are no saddle height screws protruding by using the best fit size for each saddle and if necessary shortening them a little by filing the bottom of the saddle height screw until they are exactly the right height with no protrusion above the top of the bridge saddle.

Thank you for choosing a Wudtone Tremolo ( vibrato ) Bridge. We hope you have many hours of re-energised, dynamic, tone enhanced enjoyment from your guitar.

We would be absolutely delighted to see you share your experience on any forums or indeed in email to us direct via [mail@wudtone.com](mailto:mail@wudtone.com).

If you run into any problems, need any help or have any requirements / suggestions, please do not hesitate to get in touch via [mail@wudtone.com](mailto:mail@wudtone.com) or +44 1291 671515.

Many thanks in advance  
Andy Preston

**Wudtone**  
*Guitar Innovation*